



**VoyagerBT™** is a wireless, laser bar code scanner designed for low to medium throughput Point of Sale (POS) or light warehouse applications where the convenience of a wireless hand held scanner is needed.

Sunrise 2005 Compliant

## MS9535 VoyagerBT™

### Features

- Cable-free scanning using Bluetooth® technology
- CodeGate® data transmission technology ideal for menu scanning
- Up to 12,000 scans per charge
- Adjustable volume and beeper tone
- Recharging base station with in base scanning
- Wall or countertop mounting
- 10 meter (33') working range
- Decodes RSS-14, RSS Limited and RSS Expanded bar codes
- Two way communication - user receives audible and visual confirmation of each scan

**Metrologic's VoyagerBT** offers convenience and the freedom of mobility by incorporating Bluetooth wireless technology. This latest member of the Voyager Series continues the trend of combining patented technology, high performance, and a futuristic design.

VoyagerBT provides a lightweight, comfortable, and easy to use scanning solution. The patented CodeGate feature remains at the core of the scanner's functionality. The scanner wakes automatically when the integrated IR sensor is activated. To scan a bar code, simply align the laser scan line and press the CodeGate button. The data is transmitted wirelessly to the host. Operators will

find the brightly-lit laser easy to see and to line up on a desired bar code making VoyagerBT perfect for menu scanning applications.

Scanning large or heavy products can be done quickly and easily. VoyagerBT offers check-out personnel the ability to scan bulky items without the need for unnecessary heavy lifting.

VoyagerBT includes the ability to decode Reduced Space Symbology (RSS) bar codes. VoyagerBT can be used in applications including supermarkets, hypermarkets, warehouse shopping clubs, retailers, light warehouse and manufacturing.

Bluetooth is a trademark owned by Bluetooth SIG, Inc. and is used by Metrologic under license.



# MS9535 Voyager<sup>BT</sup>™

## OPERATIONAL

Light Source	Visible Laser Diode 650 nm ± 10 nm
Laser Power	0.96 mW (peak)
Depth of Scan Field	0 mm - 203 mm (0" - 8") for 0.33 mm (13 mil) bar codes
Width of Scan Field	64 mm (2.5") @ face; 249 mm (9.8") @ 203 mm (8.0")
Scan Speed	72 ± 2 scan lines per second
Scan Pattern	Single scan line
Minimum Bar Width	0.127 mm (5.0 mil)
Decode Capability	Autodiscriminates all standard 1-D and RSS-14 bar codes; for other symbologies call Metrologic
System Interfaces	PC Keyboard Wedge, RS232, Light Pen Emulation, Stand Alone Keyboard, USB (low speed and full speed), IBM
Print Contrast	35% minimum reflectance difference
Number Characters Read	Up to 80 data characters
Roll, Pitch, Yaw	42°, 68°, 52°
Beeper Operation	7 tones or no beep
Indicators (LED)	Blue = laser on, ready to scan; Yellow (flashing) = in base/battery charging; Yellow (solid) = in base/battery fully charged; White = good read

## MECHANICAL

Height	Scanner: 198 mm (7.8"); Base: 204 mm (8.0")
Depth	Scanner: 40 mm (1.6"); Base: 61 mm (2.4")
Width	Scanner: Handle: 45 mm (1.8"); Head: 78 mm (3.1"); Base: 107 mm (4.2")
Weight	Scanner (with battery): 199 g (7.02 oz); Base: 225 g (7.94 oz)
Termination	Base station: 10 pin modular RJ45
Cable	Base station: 2.1 m (7') straight

## ELECTRICAL

Input Voltage	Scanner: 5.2 VDC ± 0.25 V; base station: 5.2 VDC ± 0.25 V
Power - Operating	Scanner: 1.2 W; base station: 0.6 W
Power - Standby	Scanner: 150 mW;
Current - Operating	Scanner: 230 mA (max) @ 5 VDC; base station: 65 mA (max) @ 5 VDC
Current - Standby	Scanner: 30 mA typical @ 5 VDC
DC Transformers	Scanner: none; base station: Class 2; 5.2 VDC @ 2 A
Laser Class	Laser Class 1 In accordance with IEC 60825-1:1993+A1:1997+A2:2001 and EN 60825-1:1994+A11:1996+A2:2001
EMC	FCC, ICES-003 & EN55022 Class B
Battery Capacity/Recharge Time	12000 scans per charge/recharge time=2.5 hrs
Radio Range	10 m (33 ft)

Operating Temperature	0°C to 40°C (32°F to 104°F)
Storage Temperature	-20°C to 50°C (-4°F to 122°F)
Humidity	5% to 95% relative humidity, non-condensing
Light Levels	Up to 4842 Lux (450 footcandles)
Shock	Designed to withstand 1.5 m (5') drops
Contaminants	Sealed to resist airborne particulate contaminants

Voyager<sup>BT</sup> is available in the following colors



ISO 9001:2000



www.metrologic.com

**USA**  
Tel. 1.800.ID.METRO  
info@metrologic.com

**Asia**  
Tel. 65.6842.7155  
info@sg.metrologic.com

**AOA (only)**  
Tel. 1.617.806.1400  
info@ooa.metrologic.com

**China (only)**  
Tel. 86.512.62572511  
info@cn.metrologic.com

**South America**  
Tel. 5511.5182.7273  
info@sa.metrologic.com

**Japan (only)**  
Tel. 81.03.3839.8511  
info@jp.metrologic.com

**Brazil (only)**  
Tel. 5511.5182.8226  
info@br.metrologic.com

**Europe**  
Tel. 49.89.89019.0  
info@europe.metrologic.com

## Scan Area

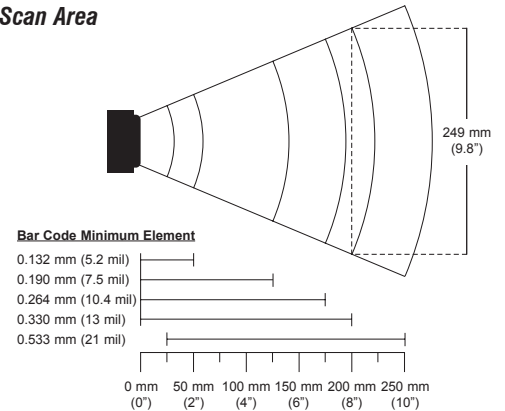

## IR Activation and Scan Width

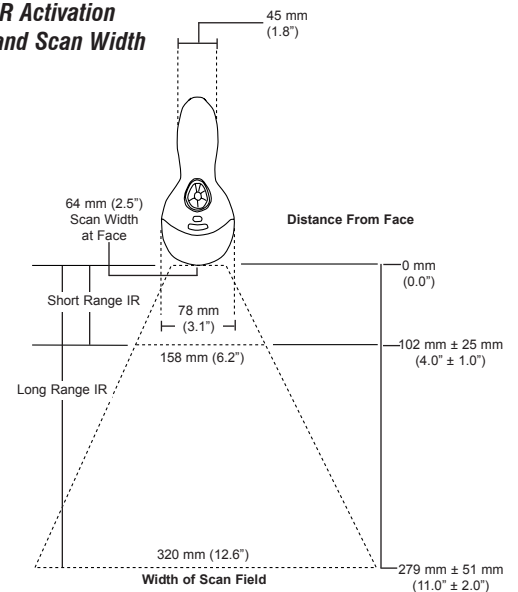

## Dimensions

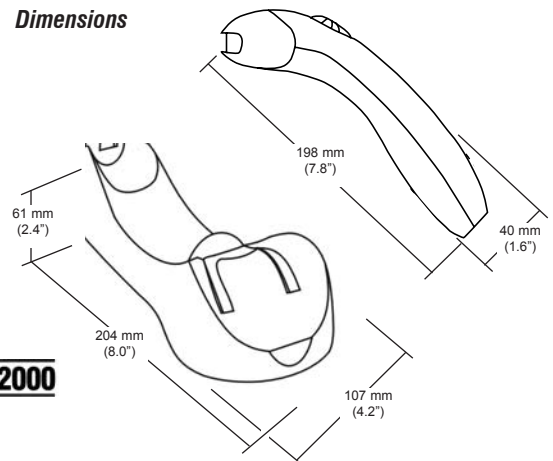

Specifications subject to change without notice.  
Printed U.S.A., Copyright September 2003  
Metrologic, All rights reserved.



DS9535